

EF- ELECTROFUSIÓN

EF MANGUITO

SDR 27,6 PE 100
AGUA: 6 BAR

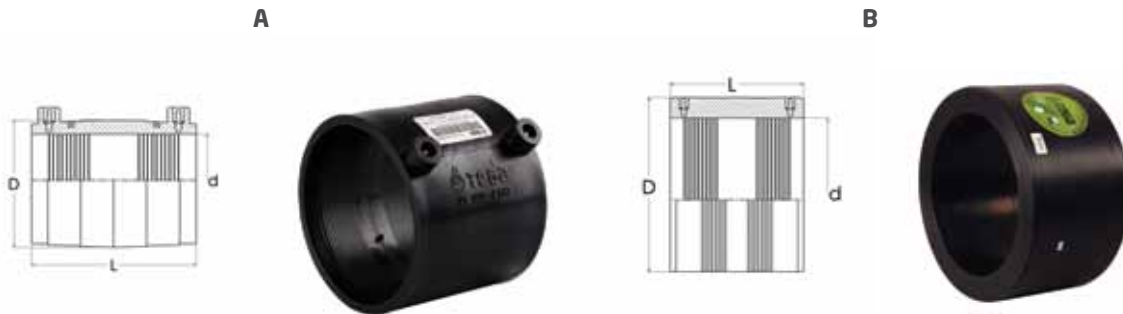

d	CÓDIGO	Kg.	D (mm)	L (mm)	caja(cm)	piezas	tipo
63	30.MA1.00.27.0063	0,12	75	83	30*40*30	50	A
75	30.MA1.00.27.0075	0,24	87	83	30*40*30	18	A
90	30.MA1.00.27.0090	0,25	103	100	30*40*30	18	A
110	30.MA1.00.27.0110	0,33	125	100	60*40*30	24	A
125	30.MA1.00.27.0125	0,38	140	100	30*40*30	16	A
140	30.MA1.00.27.0140	0,67	155	160	60*40*45	12	A
160	30.MA1.00.27.0160	0,80	175	160	60*40*45	12	A
180	30.MA1.00.27.0180	0,93	197	160	60*40*45	12	A
200	30.MA1.00.27.0200	1,15	220	165	60*40*45	8	A
225	30.MA1.00.27.0225	1,25	245	165	60*40*45	7	A
250	30.MA1.00.27.0250	1,65	275	165	60*40*45	4	A
280	30.MA1.00.27.0280	2,00	305	165	60*40*45	3	A
315	30.MA1.00.27.0315	2,50	345	165	60*40*45	3	A
355	30.MA1.00.27.0355	4,00	390	180	60*40*45	3	A
400	30.MA1.00.27.0400	5,50	440	220	60*40*45	2	B
450	30.MA1.00.27.0450	7,00	495	220	60*60*33	1	B
500	30.MA1.00.27.0500	8,70	550	220	60*60*33	1	B
560	30.MA1.00.27.0560	12,20	615	250	**		B
630*	30.MA1.00.27.0630	19,70	690	330	**		B
710*	30.MA1.00.27.0710	26,00	780	330	**		B
800*	30.MA1.00.27.0800	33,50	880	330	**		B
900*	30.MA1.00.27.0900	48,70	990	380	**		B
1000*	30.MA1.00.27.1000	72,20	1110	380	**		B
1200*	30.MA1.00.27.1200	75,40	1300	400	**		B
1400*	30.MA1.00.27.1400	122,00	1530	425	**		B
1600*	30.MA1.00.27.1600	170,40	1750	450	**		B

EF MANGUITO

SDR 17 PE100

GAS: 5 BAR

AGUA: 10 BAR

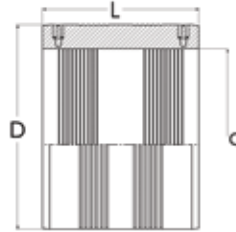

d	CÓDIGO	Kg.	D (mm)	L (mm)	caja (cm.)	piezas
160	30.MA1.00.17.0160	1,78	183	185	60*40*45	12
180	30.MA1.00.17.0180	1,60	210	185	60*40*45	8
200	30.MA1.00.17.0200	2,30	235	200	60*40*45	4
225	30.MA1.00.17.0225	3,00	265	200	60*40*45	4
250	30.MA1.00.17.0250	3,90	295	210	60*40*45	4
280	30.MA1.00.17.0280	5,00	330	220	60*40*45	3
315	30.MA1.00.17.0315	6,90	365	230	60*40*45	2
355	30.MA1.00.17.0355	9,70	415	255	60*40*45	2
400*	30.MA1.00.17.0400	14,50	470	300	60*60*33	1
450*	30.MA1.00.17.0450	20,00	530	320	60*60*33	1
500*	30.MA1.00.17.0500	27,00	590	365	**	
560*	30.MA1.00.17.0560	36,50	655	400	**	
630*	30.MA1.00.17.0630	50,00	740	420	**	
710*	30.MA1.00.17.0710	70,00	840	445	**	
800*	30.MA1.00.17.0800	86,30	935	470	**	
900*	30.MA1.00.17.0900	114,00	1050	500	**	
1000*	30.MA1.00.17.1000	147,50	1175	500	**	
1200*	30.MA1.00.17.1200	170,50	1371	500	**	
1400*	30.MA1.00.17.1400	255,30	1600	550	**	
1600*	30.MA1.00.17.1600	348,00	1829	575	**	

EF MÁNGUITO

SDR11 PE100

GAS : 10 BAR

AGUA: 16 BAR

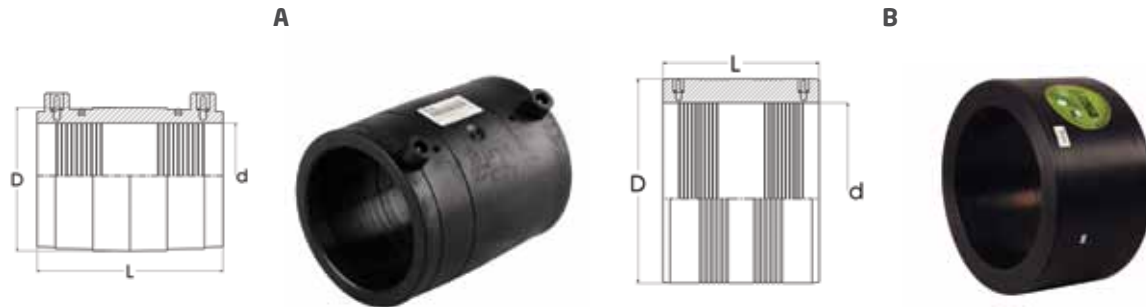

d	CÓDIGO	Kg.	D (mm)	L (mm)	caja (cm.)	piezas	tipo
20	30.MA1.00.11.0020	0,03	33	60	30*40*15	125	A
25	30.MA1.00.11.0025	0,04	41	71	30*40*15	100	A
32	30.MA1.00.11.0032	0,08	48	82	30*40*15	60	A
40	30.MA1.00.11.0040	0,09	55	86	30*40*15	40	A
50	30.MA1.00.11.0050	0,15	67	98	30*40*15	20	A
63	30.MA1.00.11.0063	0,18	80	107	30*40*30	30	A
75	30.MA1.00.11.0075	0,32	97	118	30*40*30	24	A
90	30.MA1.00.11.0090	0,65	119	148	60*40*30	25	A
110	30.MA1.00.11.0110	0,94	140	170	60*40*45	22	A
125	30.MA1.00.11.0125	1,20	160	170	60*40*45	16	A
140	30.MA1.00.11.0140	1,60	180	170	60*40*45	12	A
160	30.MA1.00.11.0160	2,00	200	188	60*40*45	12	A
180	30.MA1.00.11.0180	2,30	222	185	60*40*45	8	B
200	30.MA1.00.11.0200	3,50	247	200	60*40*30	4	B
225	30.MA1.00.11.0225	3,90	277	200	60*40*30	4	B
250	30.MA1.00.11.0250	5,30	310	210	60*40*45	2	B
280	30.MA1.00.11.0280	6,70	345	220	60*40*45	2	B
315	30.MA1.00.11.0315	9,10	390	230	60*40*45	2	B
355	30.MA1.00.11.0355	13,00	440	255	60*40*45	1	B
400*	30.MA1.00.11.0400	19,00	495	300	60*60*33	1	B
450*	30.MA1.00.11.0450	25,00	554	320	60*60*33	1	B
500*	30.MA1.00.11.0500	35,00	615	365	**		B
560*	30.MA1.00.11.0560	48,50	690	400	**		B
630*	30.MA1.00.11.0630	63,80	775	420	**		B
710*	30.MA1.00.11.0710	90,00	880	445	**		B
800*	30.MA1.00.11.0800	122,70	995	470	**		B
900*	30.MA1.00.11.0900	150,00	1100	500	**		B
1000*	30.MA1.00.11.1000	191,30	1230	500	**		B

EF MÁNGUITO

SDR 9 PE100
AGUA: 20 BAR

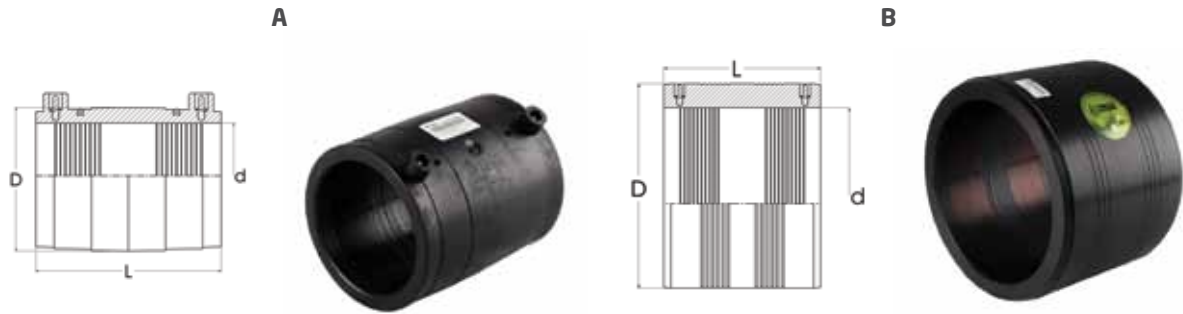

d	CÓDIGO	Kg.	D (mm)	L (mm)	caja (cm.)	piezas	tipo
63	30.MA1.00.09.0063	0,50	97	118	30*40*30	24	A
75	30.MA1.00.09.0075	0,90	115	150	30*40*30	13	A
90	30.MA1.00.09.0090	1,50	142	167	60*40*30	20	A
110	30.MA1.00.09.0110	1,70	159	170	60*40*45	16	A
125	30.MA1.00.09.0125	2,10	180	170	60*40*45	12	A
140	30.MA1.00.09.0140	2,80	200	185	60*40*45	10	A
160	30.MA1.00.09.0160	3,80	230	190	60*40*45	8	A
180	30.MA1.00.09.0180	3,60	240	190	60*40*45	4	B
200	30.MA1.00.09.0200	5,70	280	200	60*40*30	2	B
225	30.MA1.00.09.0225	6,30	305	200	60*40*30	2	B
250	30.MA1.00.09.0250	7,50	330	220	60*40*45	2	B
280	30.MA1.00.09.0280	9,50	370	220	60*40*45	2	B
315	30.MA1.00.09.0315	12,50	415	230	60*40*45	2	B
355	30.MA1.00.09.0355	17,00	465	255	60*60*33	1	B
400*	30.MA1.00.09.0400	25,70	525	300	60*60*33	1	B
450*	30.MA1.00.09.0450	34,70	590	320	60*60*33	1	B
500*	30.MA1.00.09.0500	50,50	660	365	**		B
560*	30.MA1.00.09.0560	69,80	740	400	**		B
630*	30.MA1.00.09.0630	91,40	830	420	**		B

EF MÁNGUITO

SDR 7,4 PE100
AGUA: 25 BAR

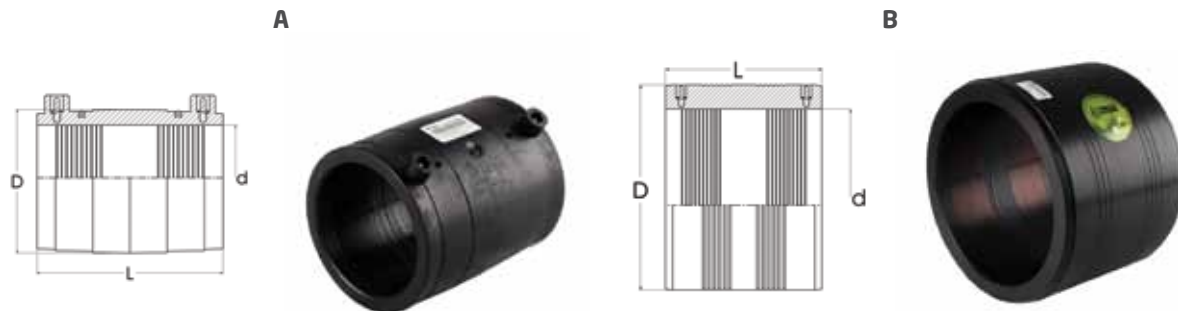

d	CÓDIGO	Kg.	D (mm)	L (mm)	caja (cm.)	piezas	tipo
63	30.MA1.00.07.0063	0,50	97	118	30*40*30	24	A
75	30.MA1.00.07.0075	0,85	115	150	30*40*30	13	A
90	30.MA1.00.07.0090	1,50	142	167	60*40*30	20	A
110	30.MA1.00.07.0110	1,70	159	172	60*40*45	12	A
125	30.MA1.00.07.0125	2,10	180	171	60*40*45	12	A
140	30.MA1.00.07.0140	2,80	200	185	60*40*45	10	A
160	30.MA1.00.07.0160	3,80	230	190	60*40*45	8	A
180	30.MA1.00.07.0180	4,10	248	190	60*40*45	4	B
200	30.MA1.00.07.0200	5,70	280	200	60*40*30	2	B
225	30.MA1.00.07.0225	6,70	310	200	60*40*45	3	B
250	30.MA1.00.07.0250	9,50	347	220	60*40*45	3	B
280	30.MA1.00.07.0280	12,00	390	220	60*40*45	2	B
315	30.MA1.00.07.0315	16,10	440	230	60*40*45	2	B
355	30.MA1.00.07.0355	21,60	490	255	60*60-33	1	B
400*	30.MA1.00.07.0400	32,60	553	300	60*60*33	1	B
450*	30.MA1.00.07.0450	43,40	620	320	60*60*33	1	B
500*	30.MA1.00.07.0500	61,50	690	365	**		B
560*	30.MA1.00.07.0560	87,90	780	400	**		B
630*	30.MA1.00.07.0630	112,70	870	420	**		B